

- NOTE:**
1. LOCATE GRADE BEAM UNDER ALL LOAD BEARING WALLS.
 2. ALL PLUMBING TO BE INSTALLED IN SLAB.
 3. DIMENSIONS DO NOT INCLUDE BRICK LEDGE
 4. SEE ELEVATIONS FOR LOCATION OF BRICK LEDGE
 5. PROVIDE SUPPORT FOR STOOP AND STEPS TO GRADE AS R'QED.

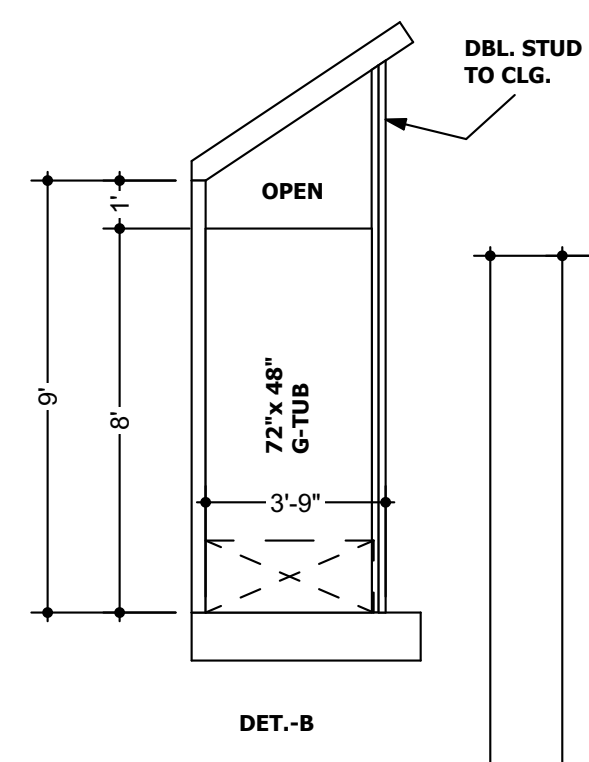

FLOOR PLAN.....2,217 S.F.
 GARAGE.....449 S.F.
 FRONT PORCH.....133 S.F.
 BACK PORCH.....120 S.F.

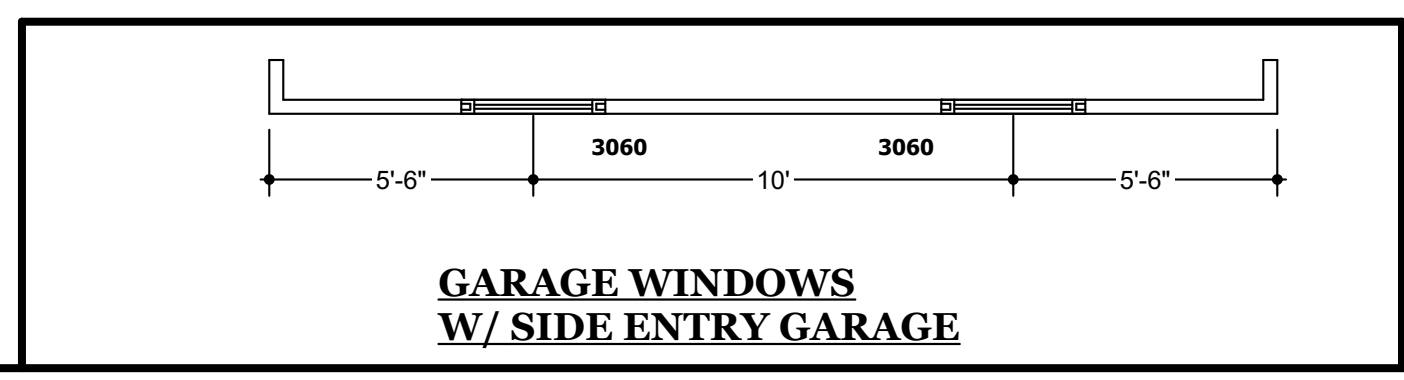
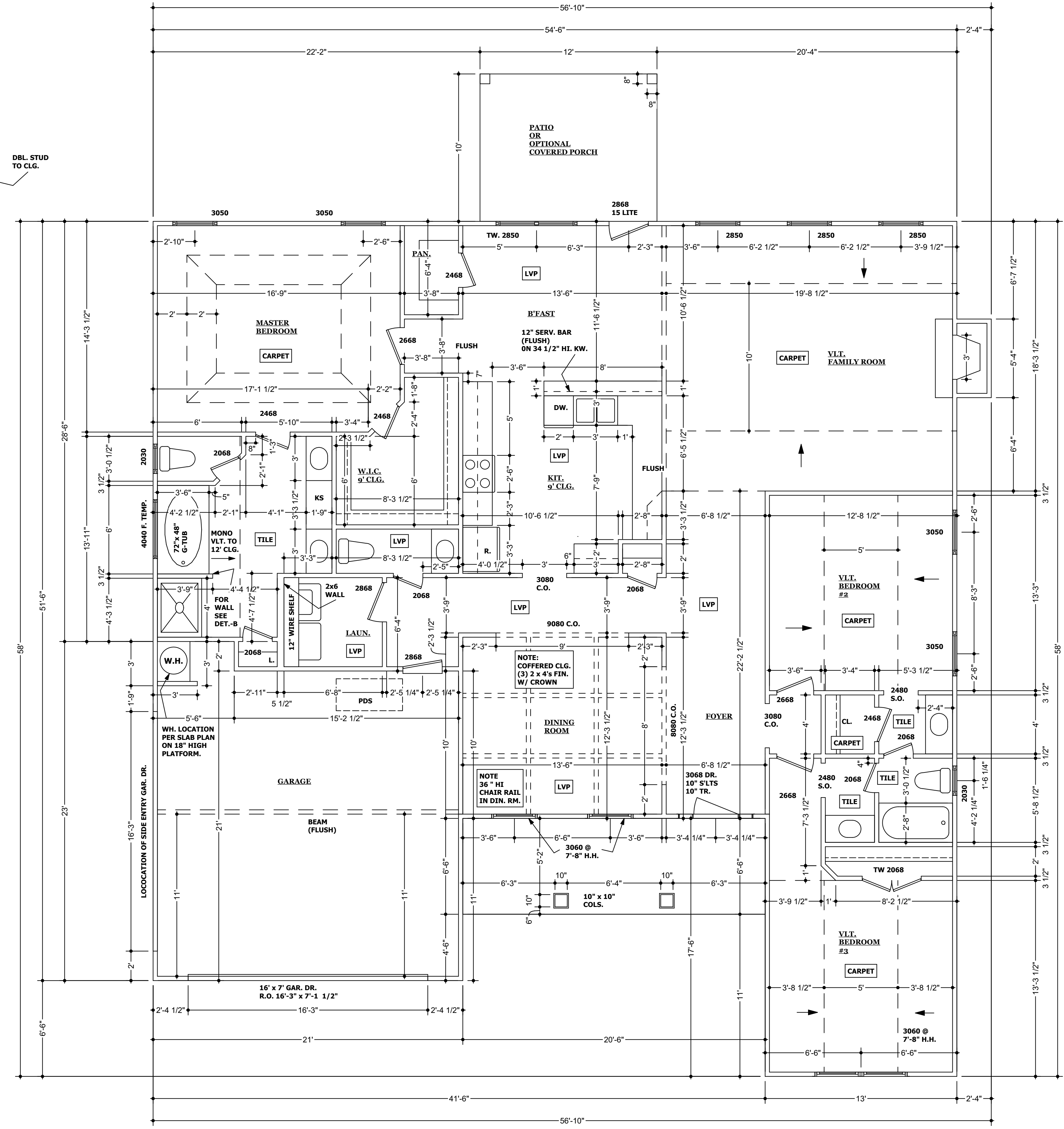

FLOOR PLAN
 1/4" = 1'-0"

