

**SLAB PLAN**  
1/4" = 1'-0"

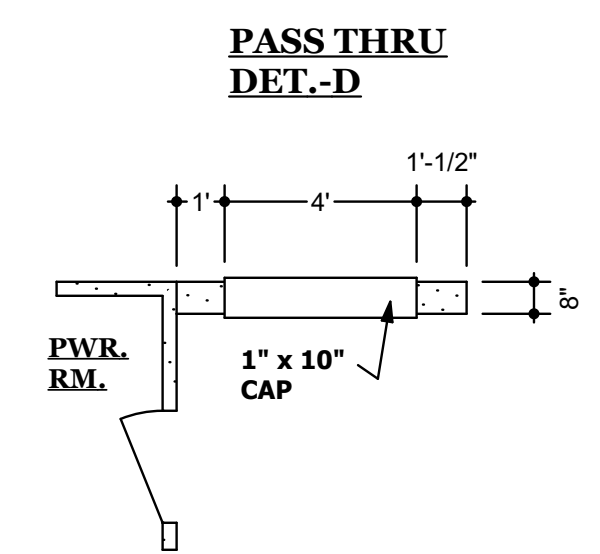
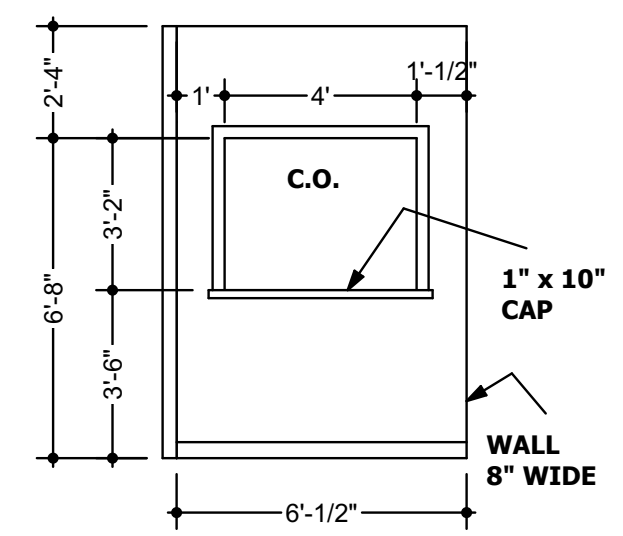
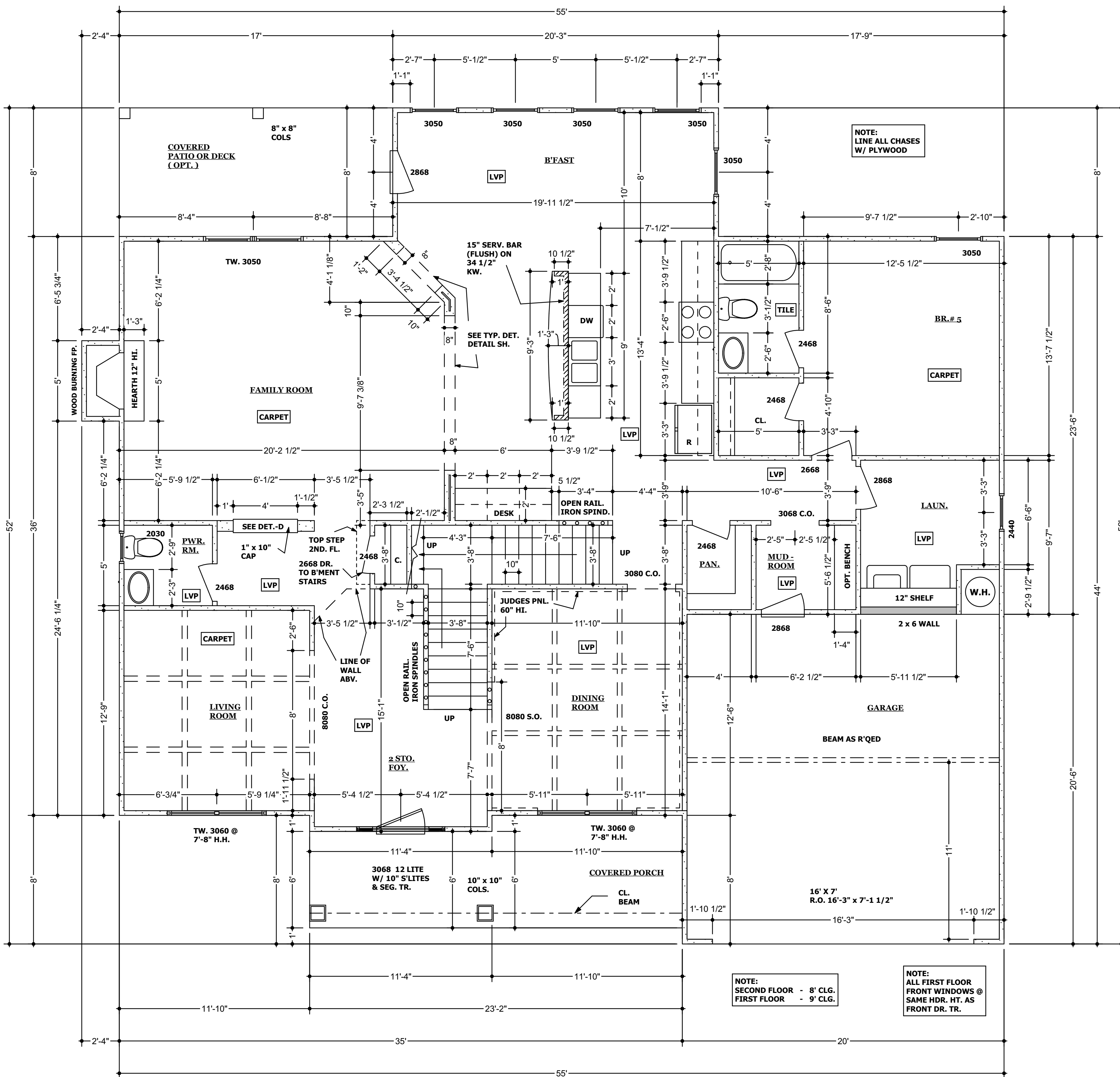

**FIRST FLOOR PLAN**  
1/4" = 1'-0"

SECOND FLOOR	2,012 S.F.
FIRST FLOOR	2,069 S.F.
<b>TOTAL HEATED FLOOR AREA</b>	<b>4,071 S.F.</b>
OPEN AREA	169 S.F.

**SIDE ENTRY GARAGE PLAN**  
1/4" = 1'-0"

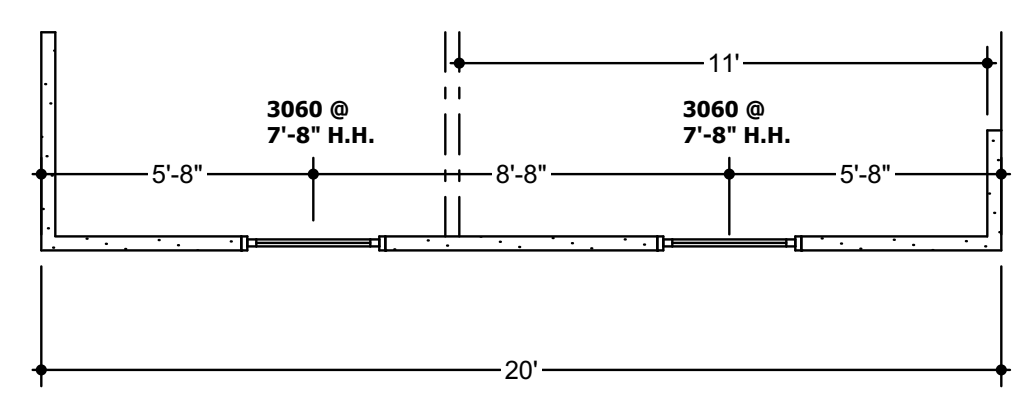

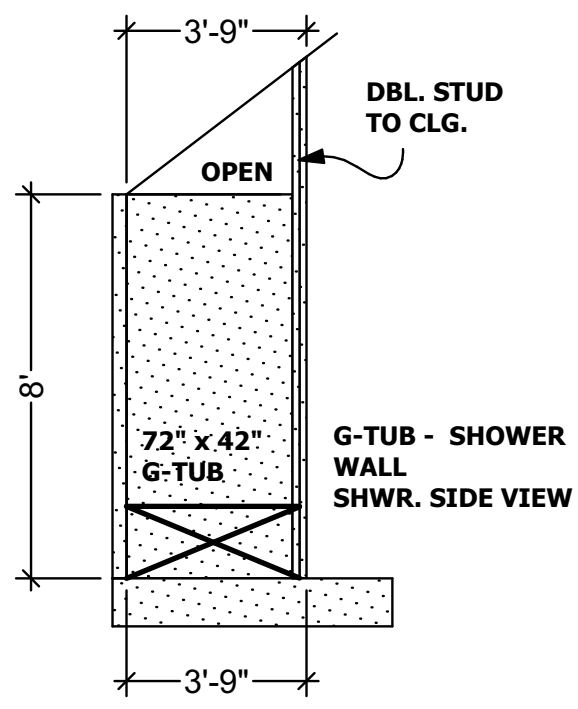
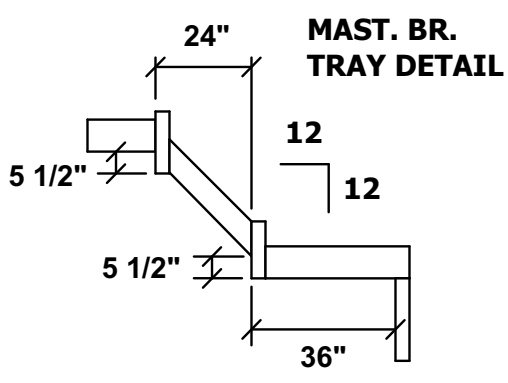
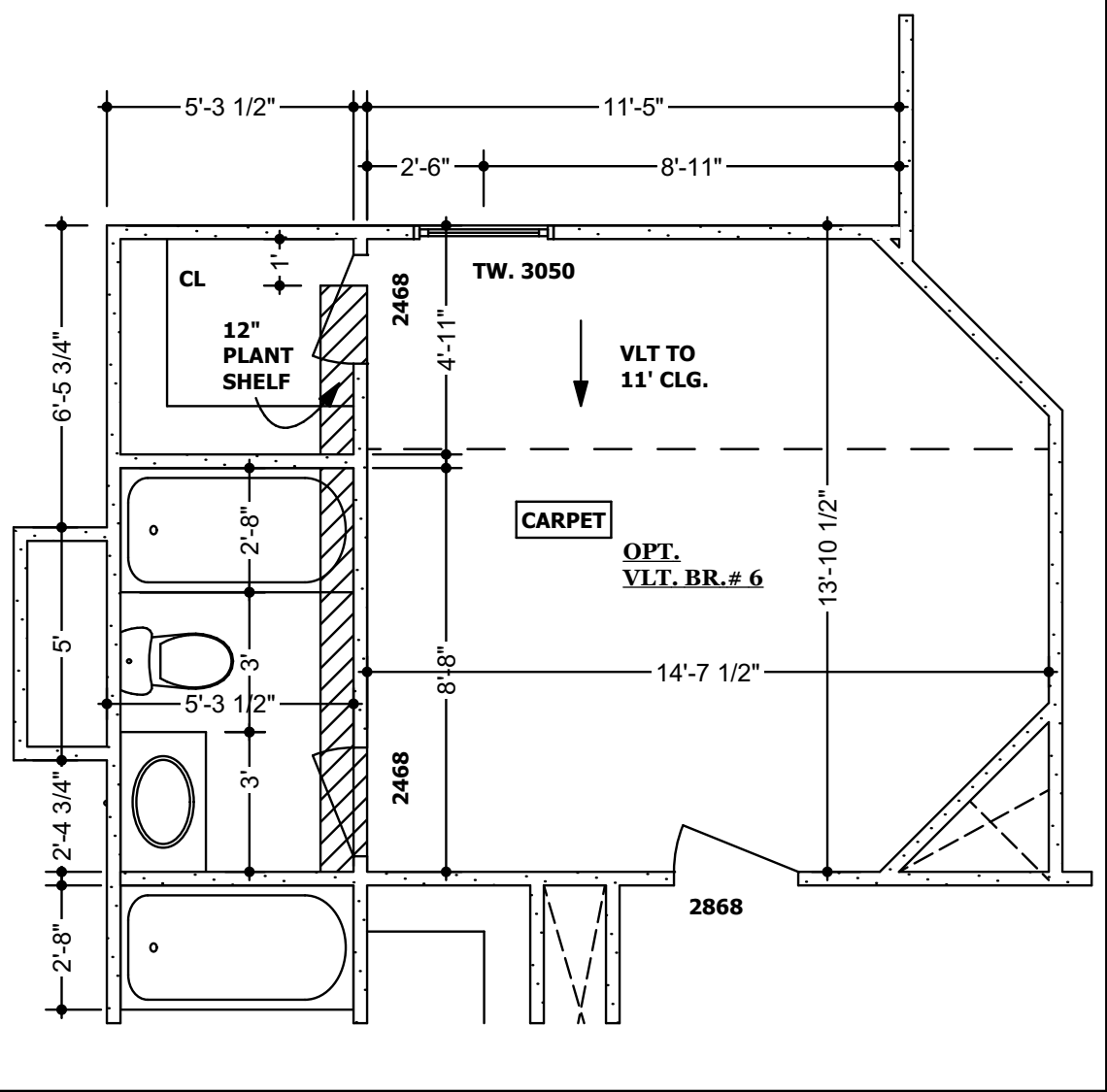

**BR.# 2 & 4 TRAY DETAIL**

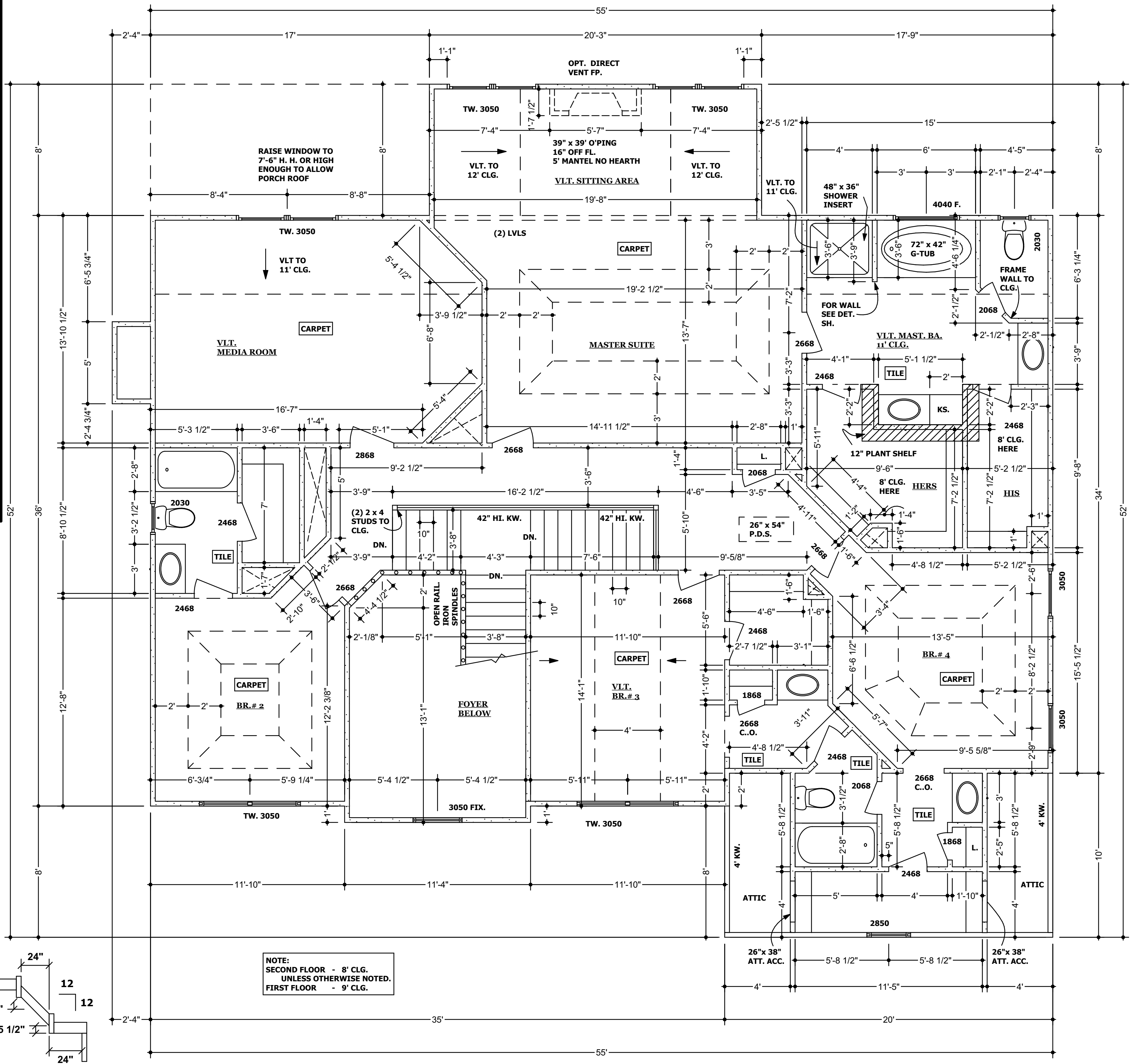
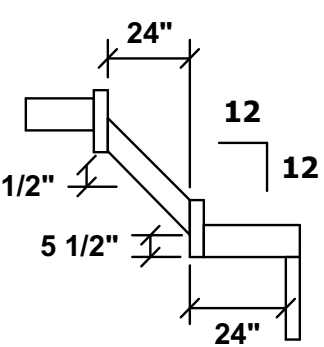

**NOTE:**  
SECOND FLOOR - 8' CLG.  
UNLESS OTHERWISE NOTED.  
FIRST FLOOR - 9' CLG.

**SECOND FLOOR PLAN**  
**1/4" = 1'-0"**

NOTE:  
ALL ELECTRICAL WORK SHALL BE PERFORMED IN ACCORDANCE  
WITH ALL APPLICABLE NATIONAL, STATE AND LOCAL CODES AND REGULATIONS.

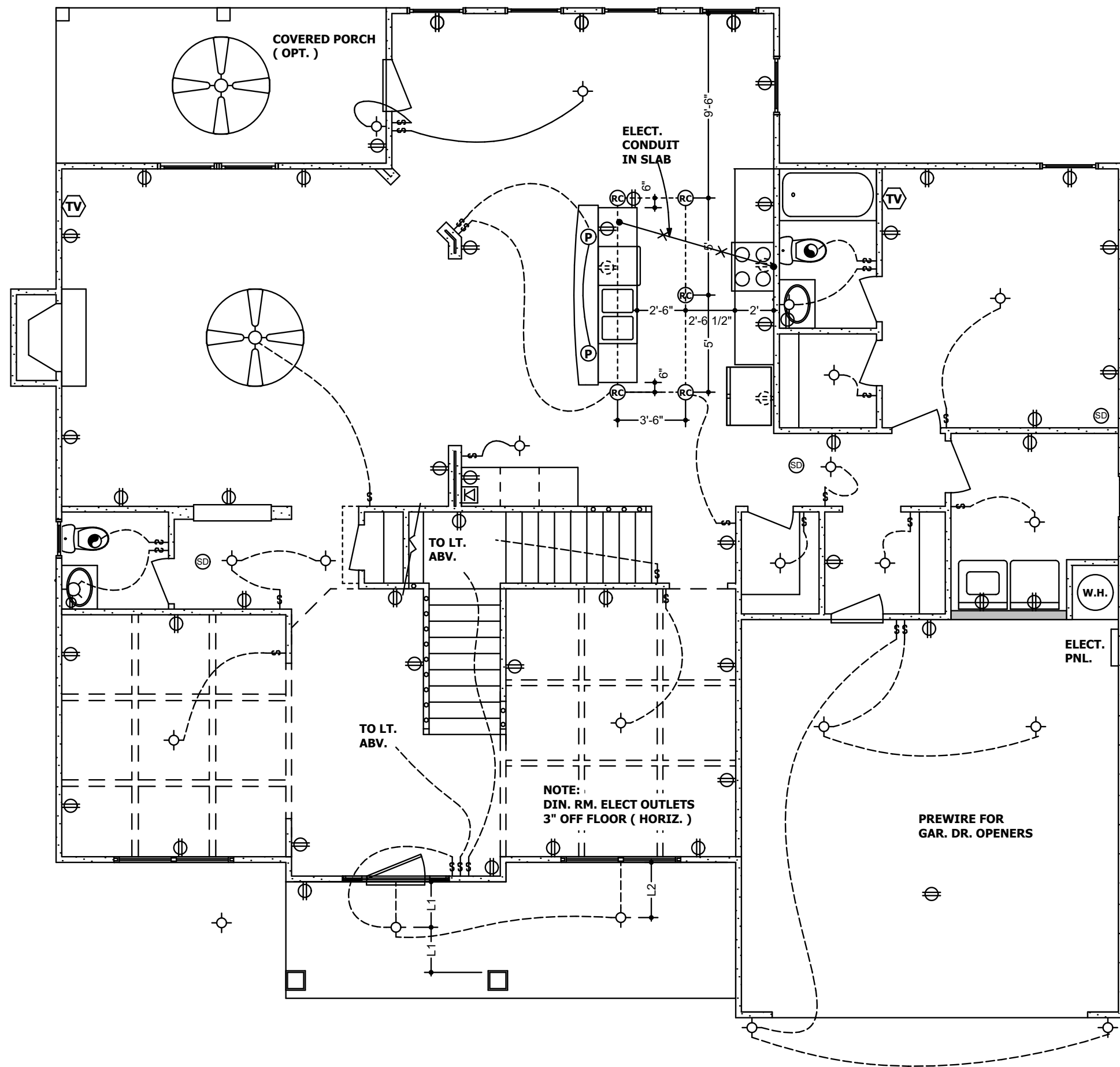

**FIRST FLOOR ELECT. PLAN  
N.T.S.**

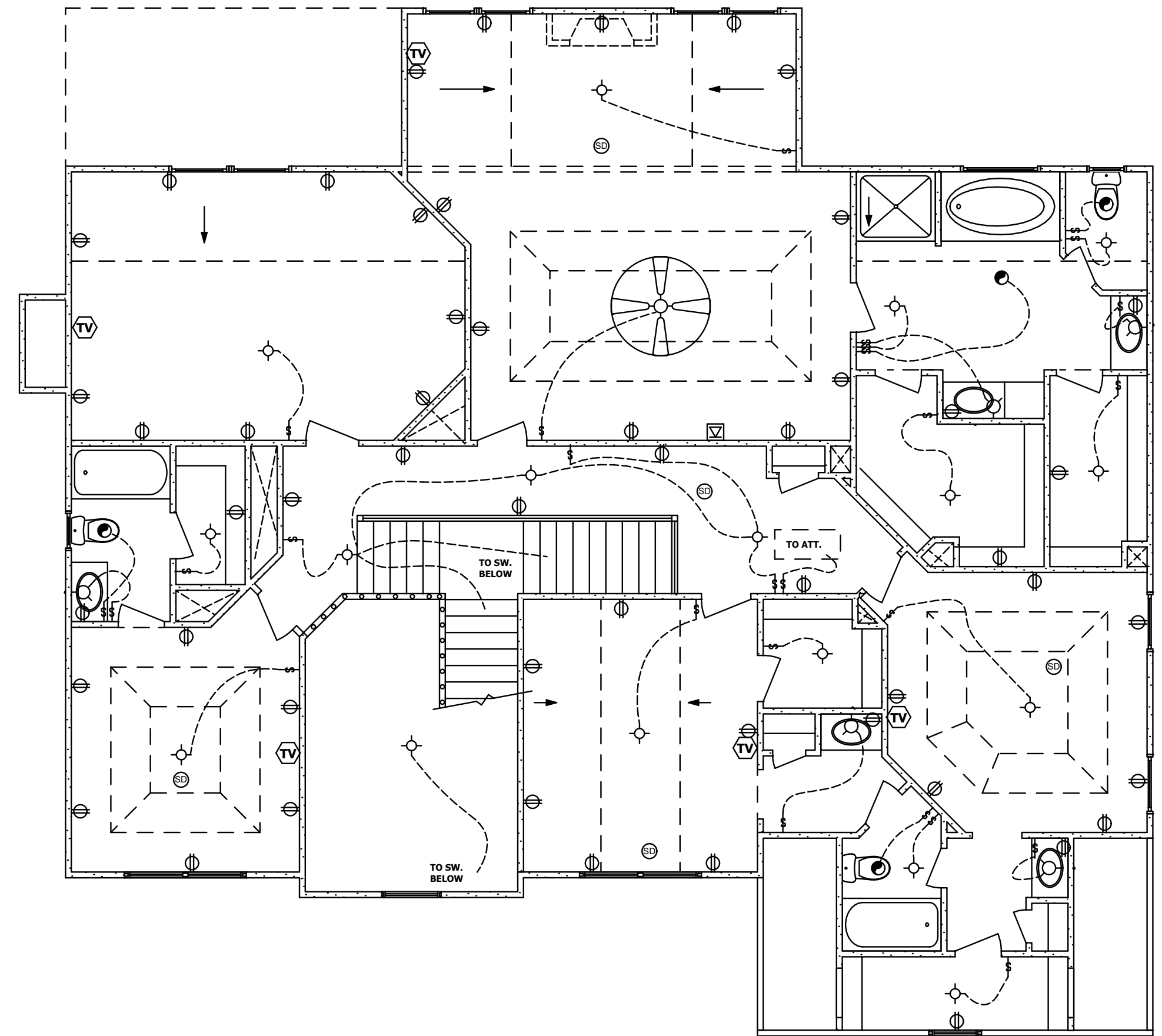

**SECOND FLOOR ELECT. PLAN  
N.T.S.**