

SLAB PLAN
1/4" = 1'-0"

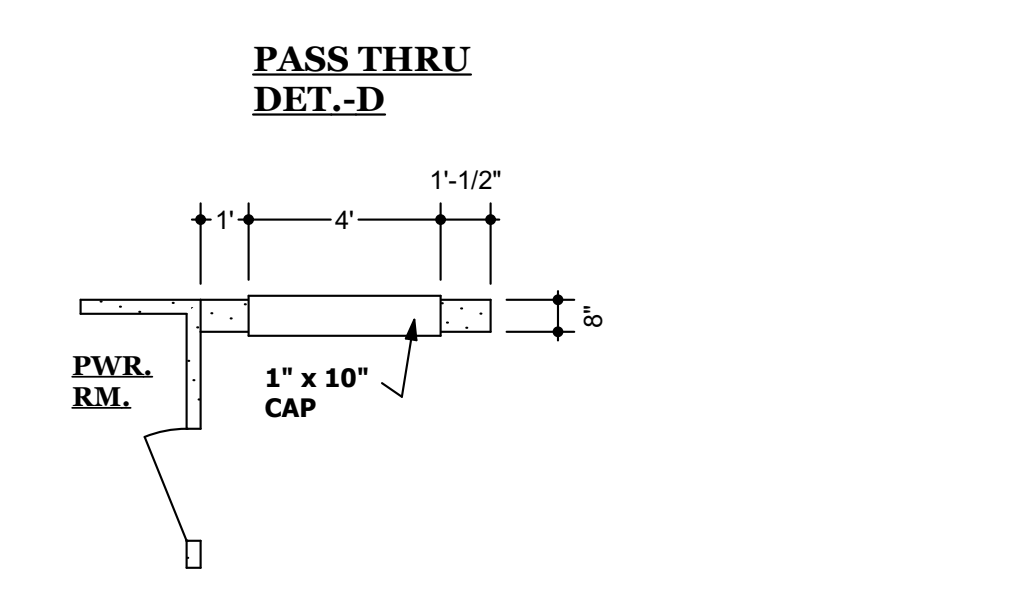
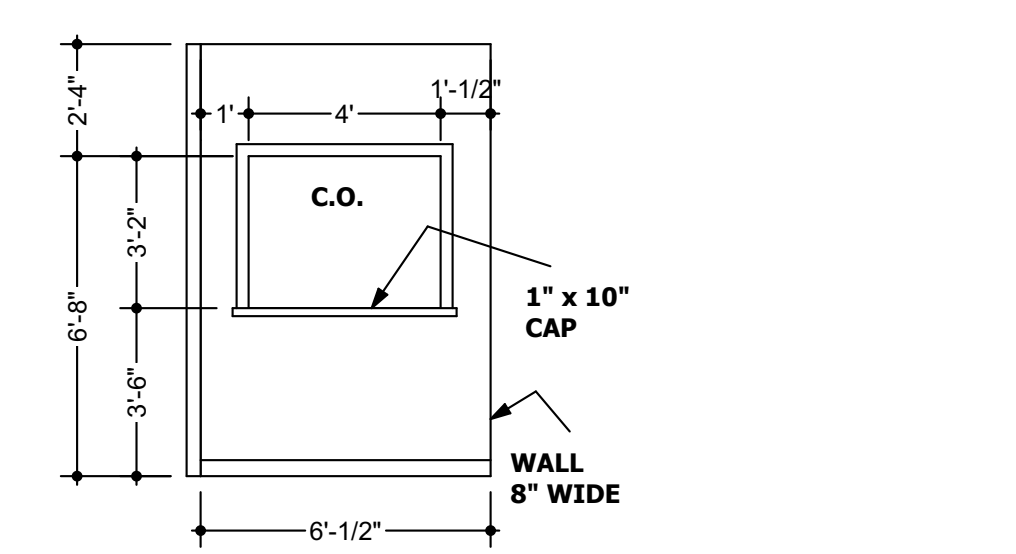
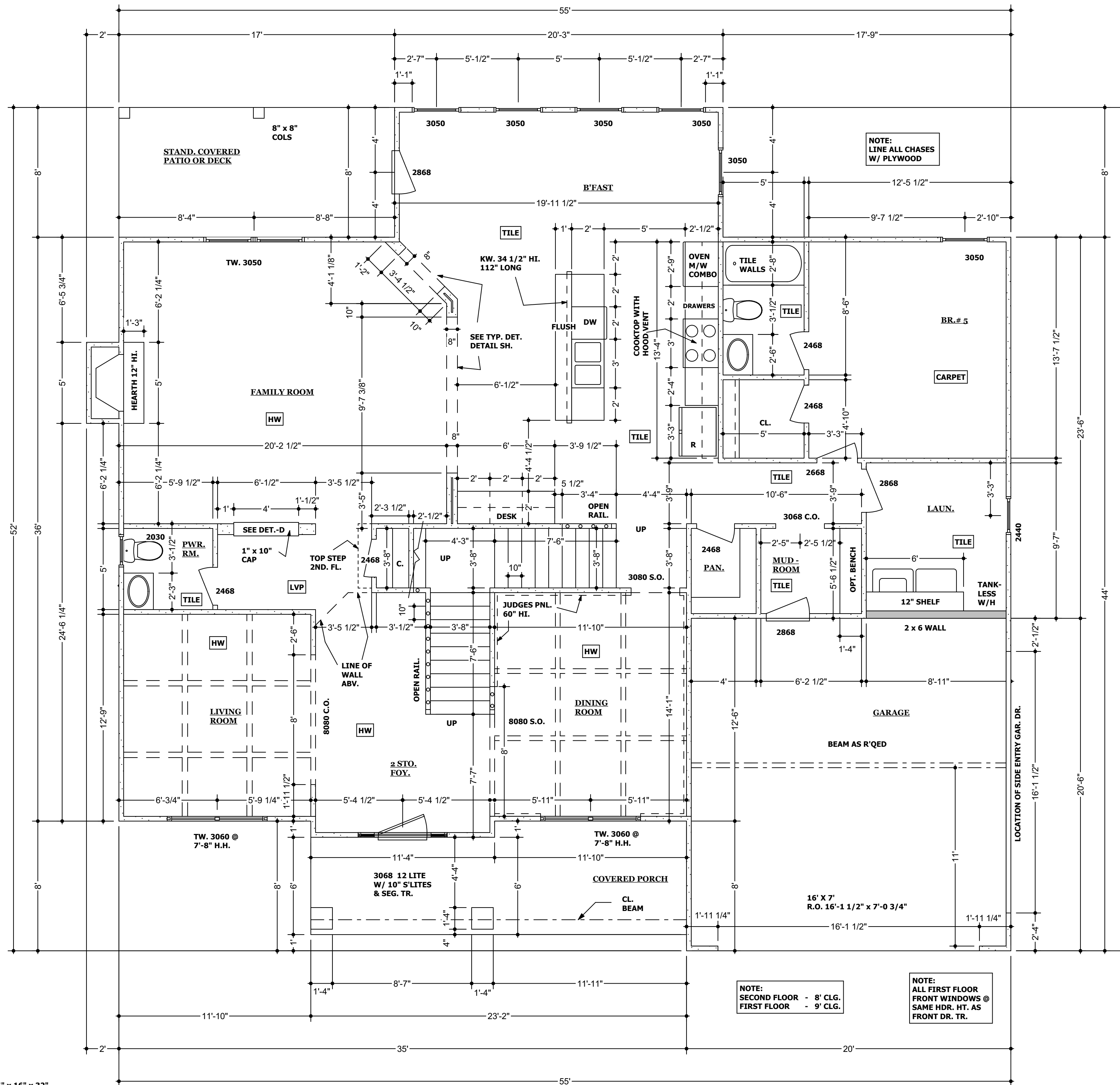

NOTE: ALL WORK SHALL BE PERFORMED IN ACCORDANCE WITH ALL APPLICABLE NATIONAL, STATE AND LOCAL CODES AND REGULATIONS.

FIRST FLOOR PLAN
1/4" = 1'-0"

SECOND FLOOR	2,012 S.F.
FIRST FLOOR	2,069 S.F.
TOTAL HEATED FLOOR AREA	4,071 S.F.
OPEN AREA	169 S.F.

SIDE ENTRY GARAGE PLAN
1/4" = 1'-0"

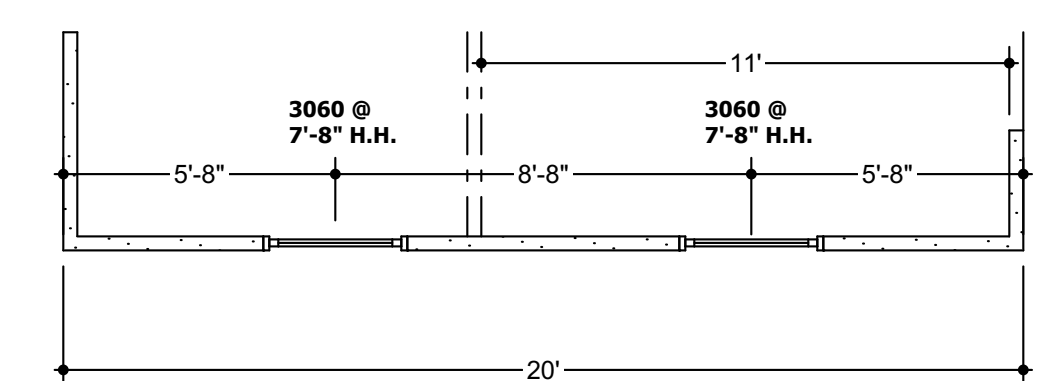

NOTE: SECOND FLOOR - 8' CLG.
FIRST FLOOR - 9' CLG.

NOTE: ALL FIRST FLOOR FRONT WINDOWS @ SAME HDR. HT. AS FRONT DR. TR.

16" x 16" x 32"
STONE BASE W/ TAP.
COL. ABV.

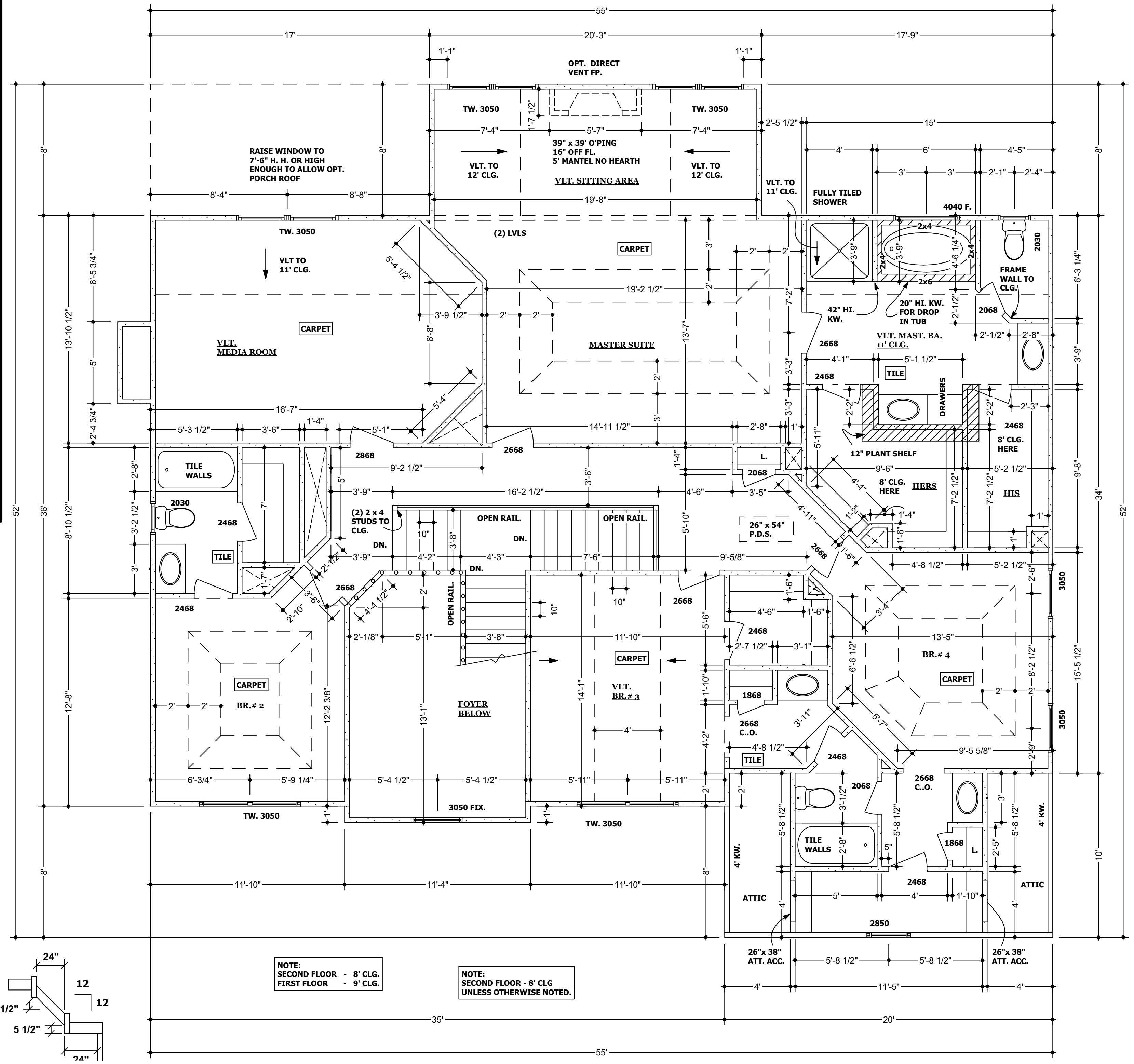
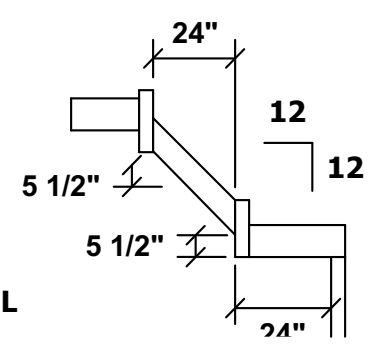
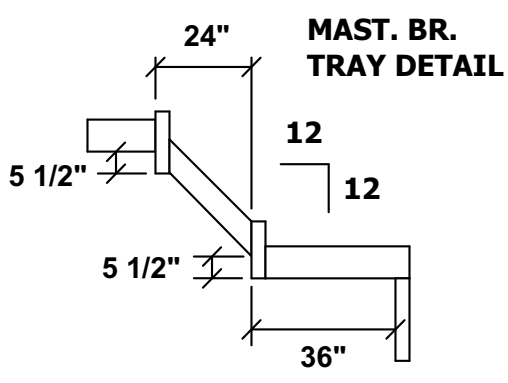
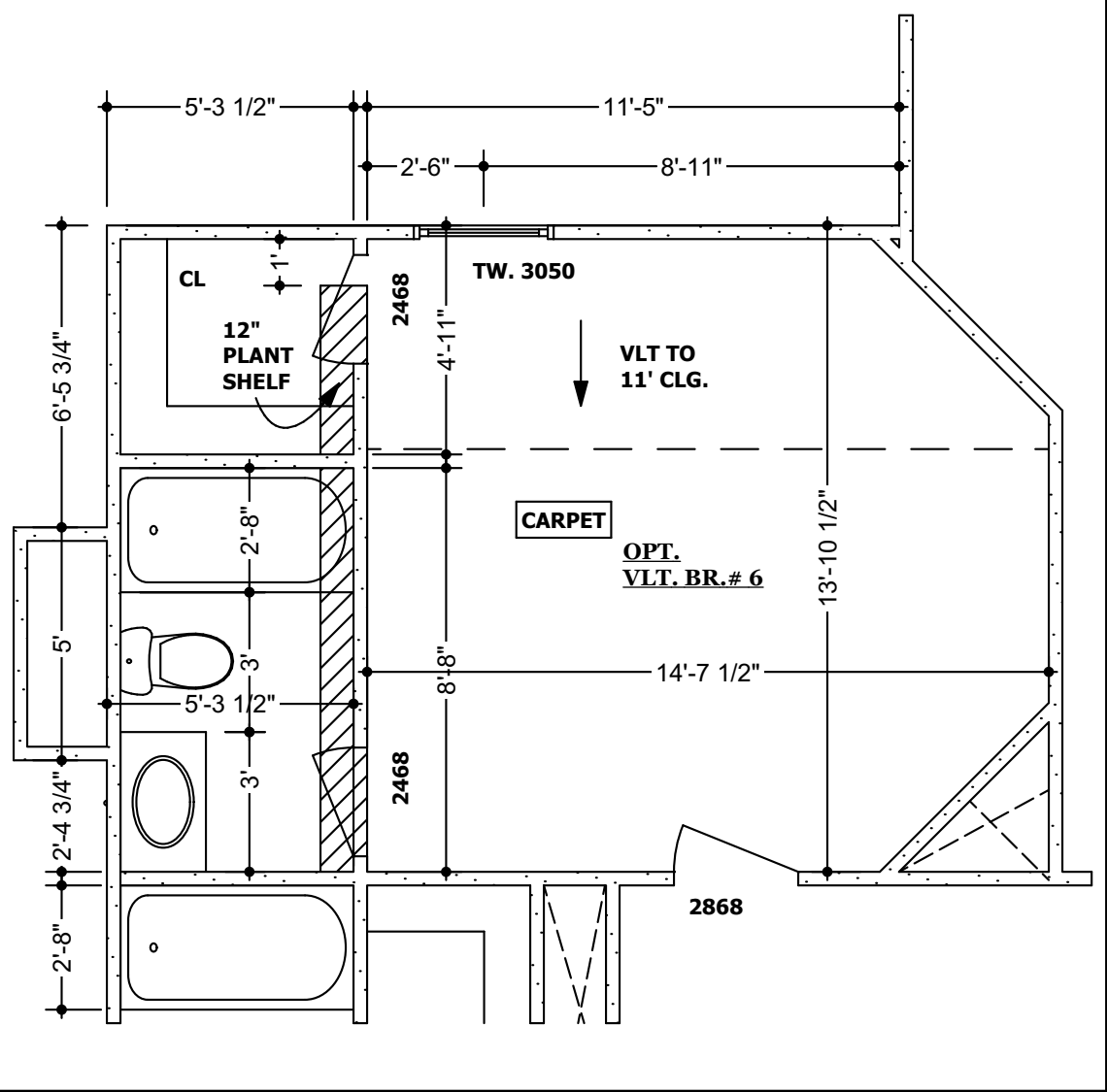

NOTE:
SECOND FLOOR - 8' CLG.
FIRST FLOOR - 9' CLG.

NOTE:
SECOND FLOOR - 8' CLG
UNLESS OTHERWISE NOTED.

SECOND FLOOR PLAN
1/4" = 1'-0"

NOTE:
ALL ELECTRICAL WORK SHALL BE PERFORMED IN ACCORDANCE
WITH ALL APPLICABLE NATIONAL, STATE AND LOCAL CODES AND REGULATIONS.

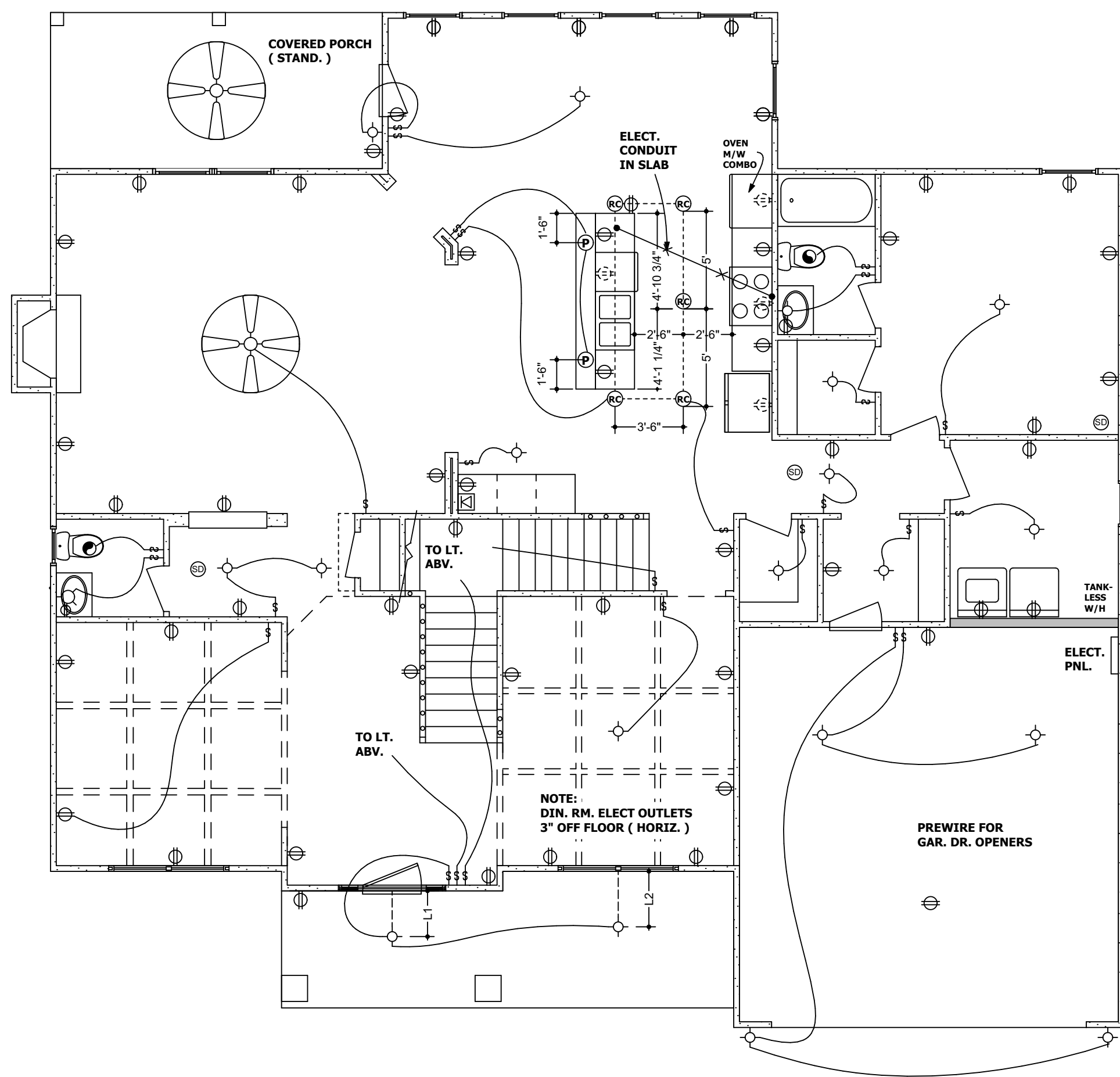

**FIRST FLOOR ELECT. PLAN
N.T.S.**

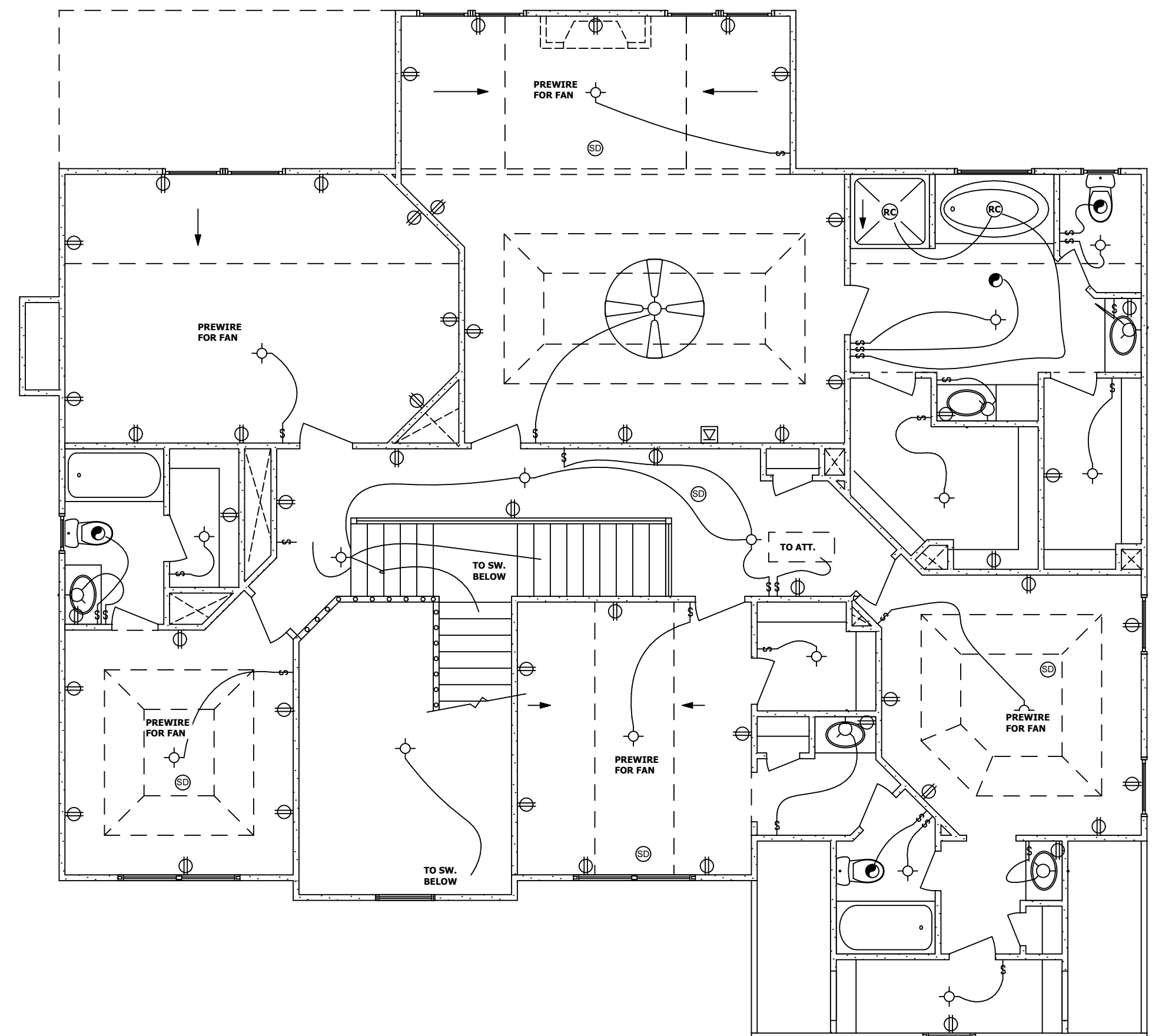

**SECOND FLOOR ELECT. PLAN
N.T.S.**