

SLAB PLAN
1/4" = 1'-0"

NOTE:
ALL WORK SHALL BE PERFORMED IN ACCORDANCE WITH ALL APPLICABLE NATIONAL, STATE AND LOCAL CODES AND REGULATIONS.

SECOND FLOOR 1,904 S.F.
FIRST FLOOR 1,710 S.F.
TOTAL 3,614 S.F.
OPEN AREA 185 S.F.

NOTE:
8' CLG. SECOND FLOOR
9' CLG. FIRST FLOOR

NOTE:
ALL WINDOW AND DOOR HDR. HTS. 6'-8" UNLESS OTHERWISE NOTED.

30" SLIDE IN W/ MICRO. HOOD

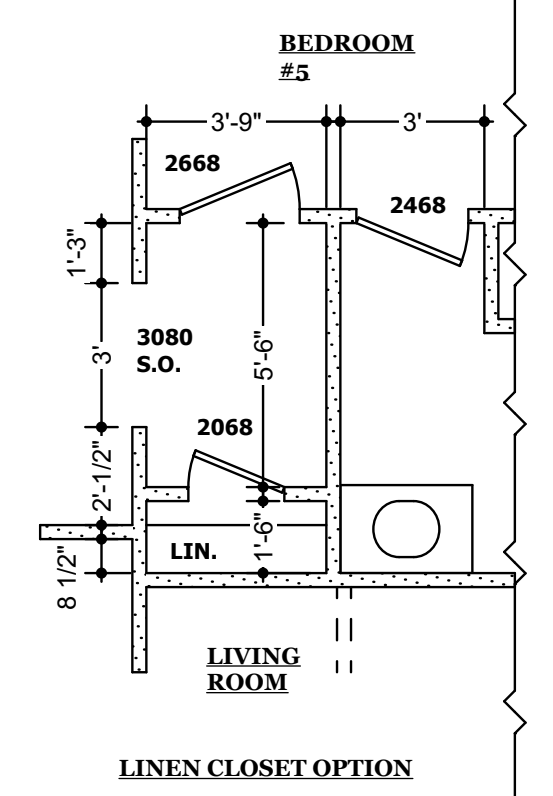
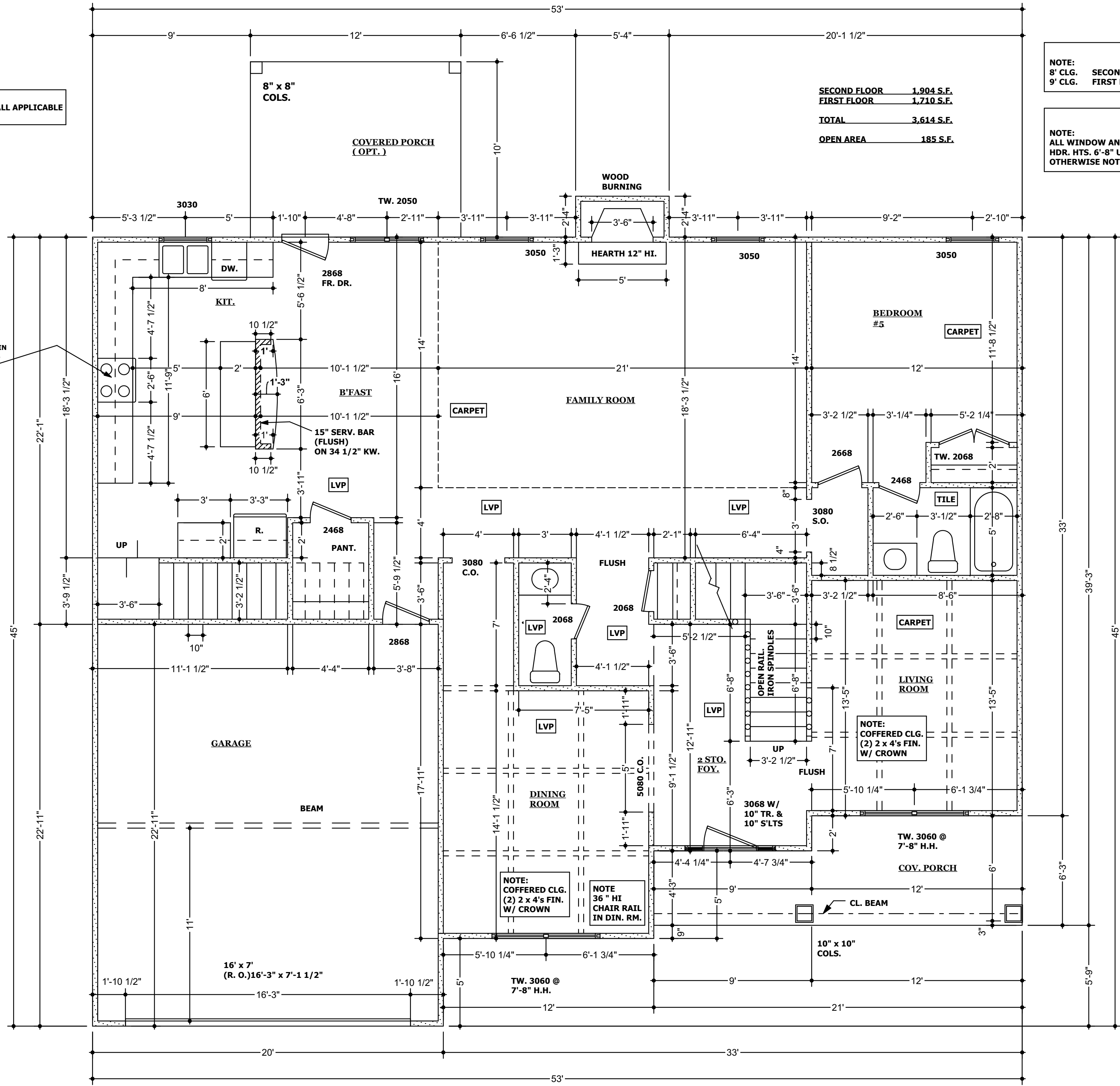

GAR. WINDOW PLAN PER SIDE ENTRY GARAGE

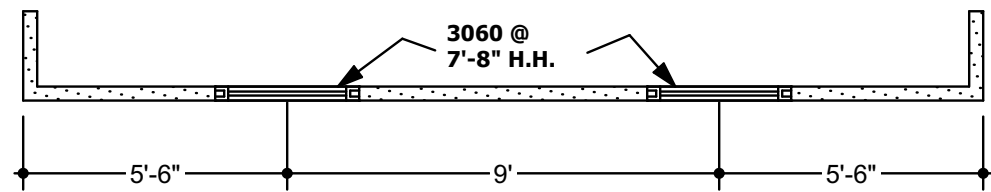

FIRST FLOOR PLAN
1/4" = 1'-0"

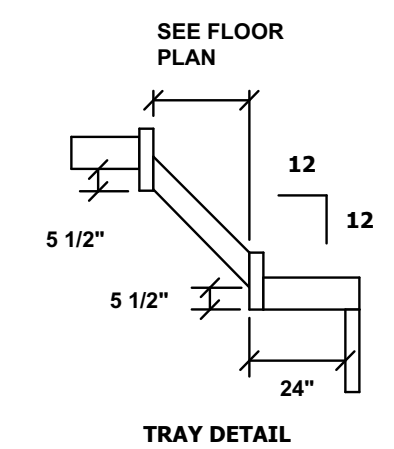
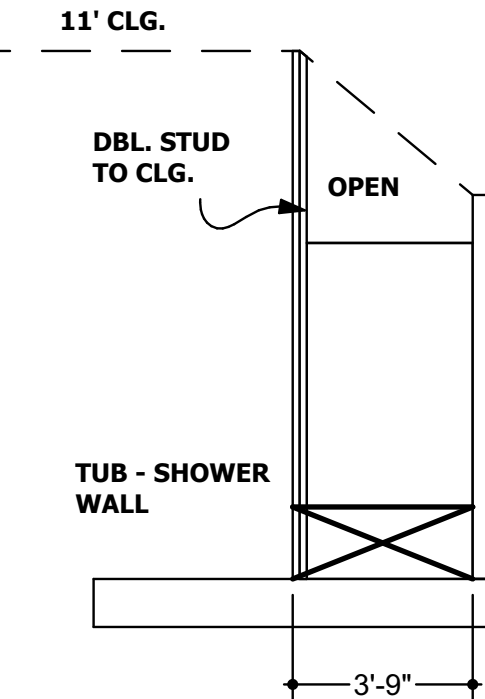
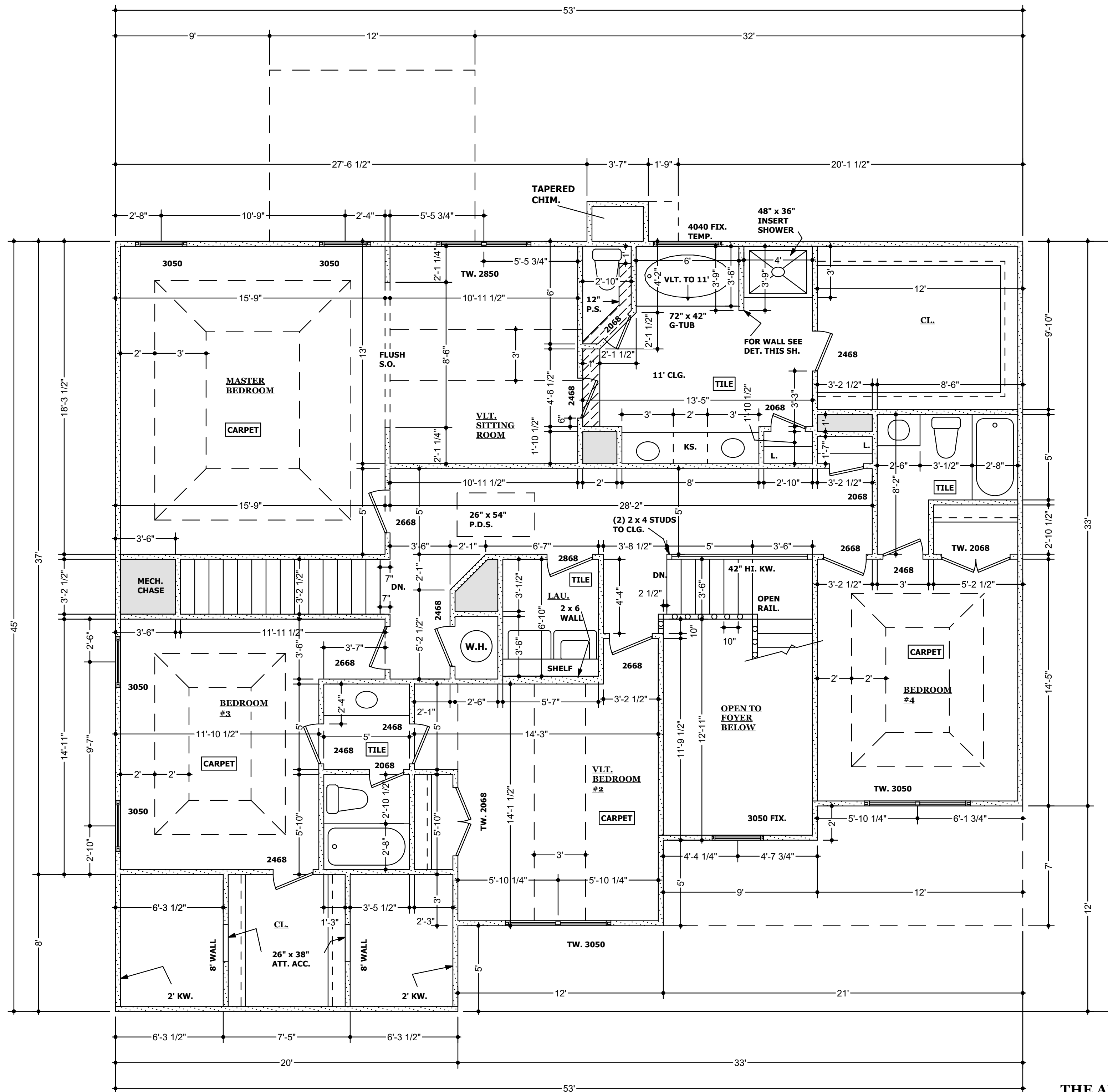

NOTE:
 8' CLG. SECOND FLOOR
 9' CLG. FIRST FLOOR

SECOND FLOOR PLAN
 1/4" = 1'-0"

NOTE:
ALL ELECTRICAL WORK SHALL BE PERFORMED IN ACCORDANCE
WITH ALL APPLICABLE NATIONAL, STATE AND LOCAL CODES AND REGULATIONS.

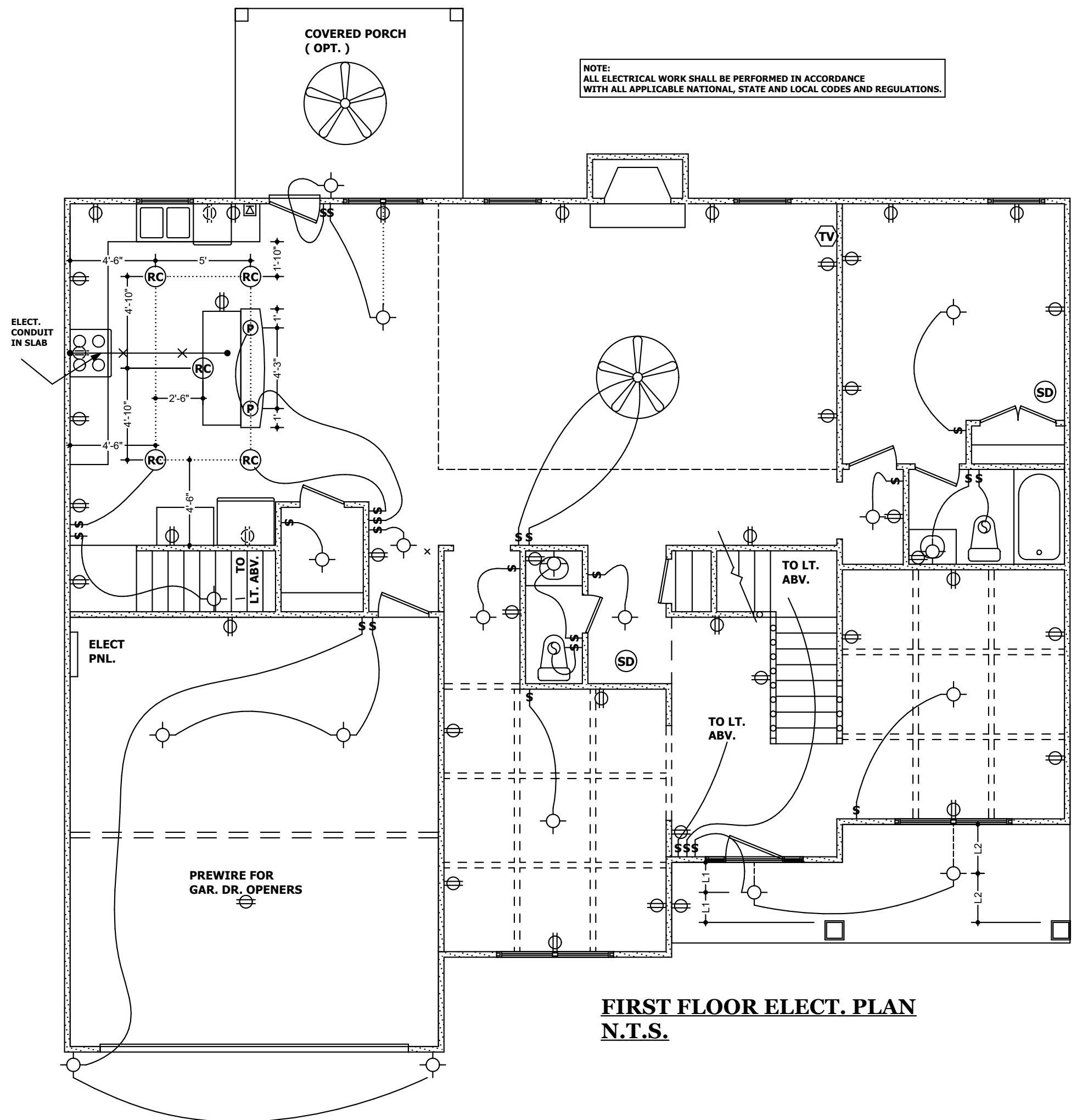

**SECOND FLOOR ELECT. PLAN
N.T.S.**

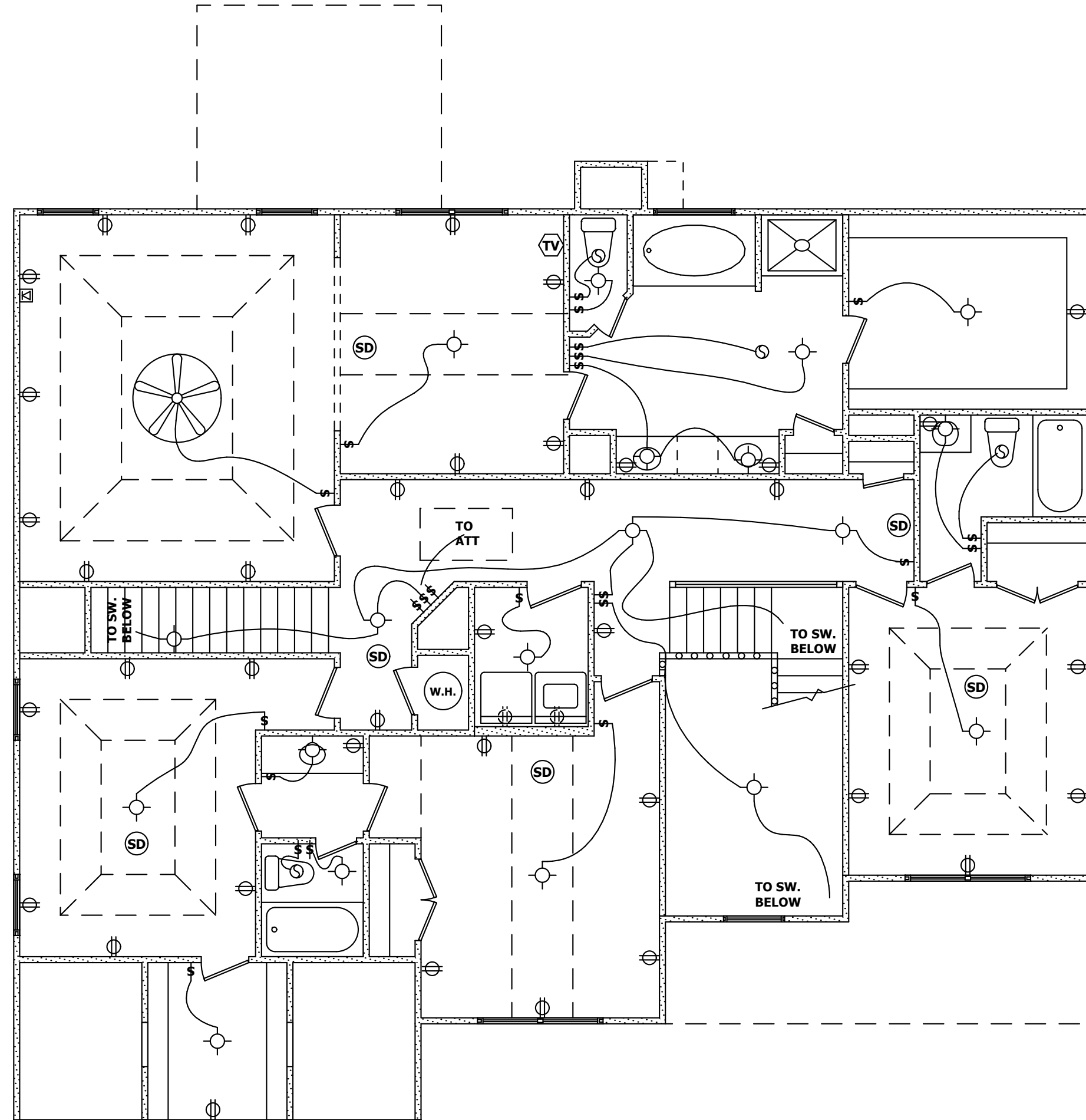

**FIRST FLOOR ELECT. PLAN
N.T.S.**